

Periodical Maintenance Chart

	Item	First month	Every month	Every 3 months	Every 6 months	Every 1 year	Note
1	Motor				I		
2	Motor Controller				I		
3	Battery	I	I				
4	Charger	I	I				
5	DC to DC Converter	I	I				
6	Tire	I	I				
7	Tire Pressure	I	I				
8	Brake Clearance	I	I	A			
9	Light / Electrical System / Meter	I	I				
10	Electric Throttle Operation			I			
11	Steering Handlebar				I		
12	Bolt / Screw / Nut Tightness	I	I				
13	Main Stand / Spring				I		
14	Suspension / Oil Leakage			I			
15	Frame Parts Lubrication				L		
16	Transmission Belt					I	

I-Inspection A-Adjustment R-Replace C-Clean L-Lubrication

Non after sales scope

- Battery pack over warranty period;
- The appearance of lithium battery pack is seriously damaged;
- The lithium battery pack is changed without permission;
- The lithium battery group has fallen and bumped, causing structural damage;
- If the laser code of lithium battery pack is damaged, it cannot be judged whether it is produced ;
- Battery damage caused by water immersion or chemical corrosion inside the lithium battery pack;
- External short circuit of lithium battery pack;
- The lithium battery pack does not match the charger or vehicle type (the charger specially provided or recognized is not used);
- The lithium battery pack exceeds the warranty period;
- Battery that has been identified as counterfeit or forged; battery code has been tampered and erased artificially; font size and format of battery code do not conform to our technical standards;
- After sales turnover battery;
- Battery damage caused by force majeure (including natural disasters such as typhoon, earthquake, flood and hail);
- Other exemption conditions protected by relevant laws and regulations.
- Other quality problems of lithium battery pack caused by customer

This manual describes the correct usage of this vehicle including safe riding, simple inspection methods and so on.

For a more comfortable and safer riding, please read this manual carefully.

For your benefit, please ask your SYM dealer the operating manual and read the following :

- Correct usage of the vehicle.
- Pre-delivery inspection and maintenance.
- Usage of warranty, warrant contents, and warranty period.

In case the vehicle's specifications and construction are modified and different from the photos and diagrams on the owner's manual / catalogues, the specifications and construction of the actual vehicle shall prevail.

◎Safety Suggestion◎

We concern the safety of both you and your scooter, thus, in this manual we provide safety suggestions of the scooter usage. Please read carefully and follow the safety suggestions. These safety suggestions indicate some potential dangers which may cause injury; each safety suggestion has specific warning mark, symbol, or notation illustrated below:

Warning

Disobeying of this mark may lead to serious injury or even death.

Warning: improper use of lithium battery may cause electric shock or fire, resulting in personal injury or death.

Caution

Disobeying of this mark may lead to hurt or even serious injury.

Attention

Disobeying of this mark may lead to hurt.

- ◎Every safety suggestion has notation telling you what danger may happen and how to avoid or reduce the risk.
- ◎In addition to the three safety suggestions mentioned before, there is also another important mark in this manual—Note ; disobeying this mark may result malfunction of your scooter.

1. Contents	1
2. Control Location	2
3. Safe Riding	3
4. Use Genuine Spare Parts	4
5. Use of Each Component	5
Gauges	5
Main Switch / Handlebar Lock Operation	7
Use Of Buttons	8
Note on Starting to Ride	9
Brake	9
Parking / Shutting Off	9
Electric Throttle Instruction	9
Battery Charging Instruction	10
Battery Charging usage notes	11
Instruction Of Battery Usage	12
Battery Charger Usage Method	13
6. Inspection and Maintenance before Riding	14
Controller Unlocking	14
Battery over temperature protection	14
Tire Inspection	15
Steering Handlebar Inspection	15
Inspection and adjustment of brake free play	17
Maintenance	18
Motor Usage Notes	18
Motor Controller Usage Notes	19
7. Troubleshooting	20
8. Specification	21
9. SYM Electric Scooter Q & A	22

2.CONTROL LOCATION

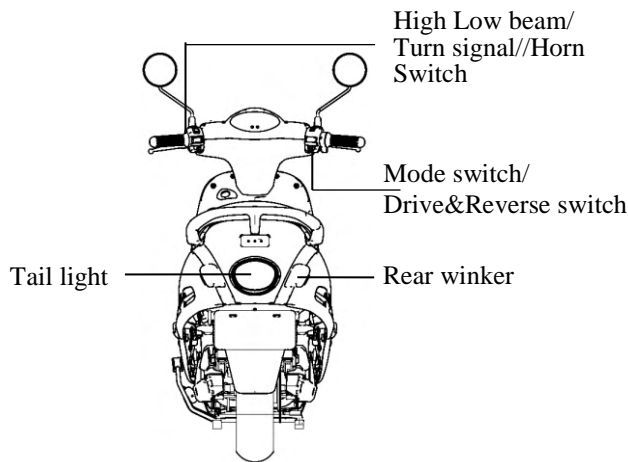
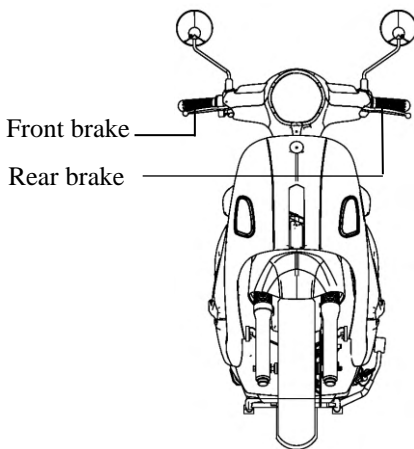
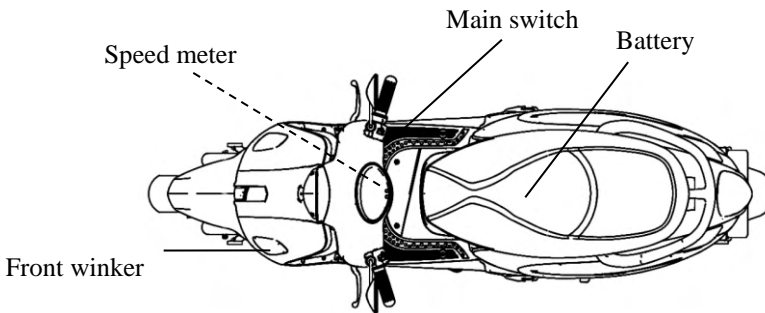
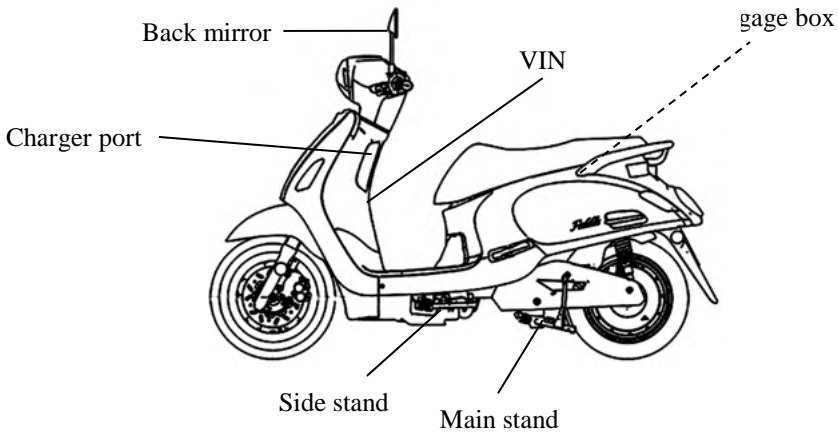

This manual describes the correct usage of this vehicle including safe riding, simple inspection methods and so on.

For a more comfortable and safer riding, please read this manual carefully.

For your benefit, please ask your SYM dealer the operating manual and read the following :

- Correct usage of the vehicle.
- Pre-delivery inspection and maintenance.

In case the vehicle's specifications and construction are modified and different from the photos and diagrams on the owner's manual / catalogues, the specifications and construction of the actual vehicle shall prevail.

3.SAFE RIDING

It is very important to be relaxed and wear properly while riding, observe traffic regulations, do not rush, always ride carefully and relaxed.

Usually, most people would ride their newly bought vehicle very carefully, but after they become familiar with their vehicle, they tend to become reckless which may result in an accident.

To remind you :

- Please wear a helmet, and properly tighten the helmet belt when riding.
- Clothes with open or loose cuffs may be blown by wind and cause the cuffs caught on the steering handlebar and thus affects riding safety. So put on clothes with tight sleeves.
- Hold the steering handlebar by both hands when riding. Never ride with only one hand.
- Observe the speed limit.
- Wear suitable low-heel shoes.

Perform periodical maintenance and inspection in accordance with the schedule.



CAUTION :

- Modified vehicle will affect its structure or performance, and cause poor engine operation or exhaust noise, which will result in shorter vehicle service life.
Besides, modification is illegal and does not conform to the original design and specifications.
A modified vehicle will not be covered by warranty. Therefore, do not modify your vehicle at will.
- Tire and rim modifications will make it unsafe to ride and may cause severe injury or death.

Keep your body such as shoulders, arms, palms, and waist relaxed and ride with the most comfortable posture in order to react quickly when necessary.

- Riding posture will greatly affect riding safety. Always keep your body's gravity in the center of the seat. If your body's gravity is on the rear part of seat, the front wheel load will be reduced, and this will cause the steering handlebar shaking. It is dangerous to ride a vehicle with an unstable handlebar.
- It will be much easier to make a turn when the rider inclines his body inward. On the contrary, the rider will feel unstable if his body and the vehicle do not incline when making a turn.
- The vehicle is hard to control on a bumpy, unlevelled, unpaved road. Try to know the road conditions in advance, slow down and use your shoulder's force to control the handlebar.
- Suggestion: Do not load unnecessary objects on the front floor panel; avoid affecting the riding safety and the operation of steering handlebar.

 **CAUTION :**

The rider's feeling on the handlebar is slightly different with or without a load. Overload may cause the handlebar to swing and affect the riding safety.

Therefore, do not overload your vehicle.

- Overload will cause the vehicle become unstable and hard to control, it may cause serious damage to the tires and rims; it may also change the center of gravity, which could result in an accident that could cause injury or death. Do not exceed the maximum authorized load.

If equipped with USB charging function, do not use it in rainy days

4.USE GENUINE SPARE PARTS

To maintain the vehicle's best performance, each part's quality, material, and machined precision must conform to the design requirements.

“**SYM Genuine Spare Parts**” are made from the same high quality materials used for the original vehicle.

No parts would be sold to the market until they could meet the designed specifications through sophisticated engineering and stringent quality control.

Therefore, it is necessary to purchase “**SYM Genuine Spare Parts**” from “**SYM Authorized Dealers or Franchised Dealers**” when replacing spare parts.

If you buy the cheap or fake substitute parts from the market, neither quality nor durability will be guaranteed.

Also, it may result in unexpected troubles and reduce the vehicle's performance.

- Always use **SYM Genuine Spare Parts** to ensure its long service life.

Basic Controls of meter

GAUGES

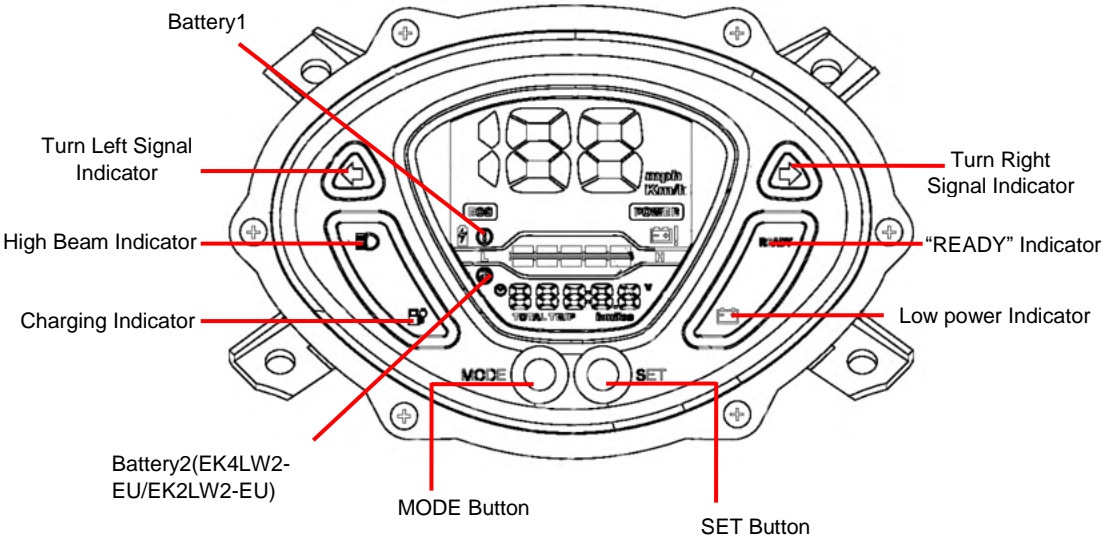

Speedometer

- This shows the speed in kilometers per hour (km/h).

Odometer

- This odometer shows the total kilometers this motor has been driven.

Turn Signal Indicator

- The left or right Indicator will be flashing according to the operated directions of turn signal light switch when it is turned on.

High Beam Indicator:

- This indicator comes on when the high beam headlight switch is turned on.

Charging Indicator

- When the battery is being charged, the charging indicator is on.

Low Power Indicator

- When the battery voltage of the vehicle is insufficient and the battery power display is only one grid, this light will indicate that the battery needs to be charged with a red light

Battery 1,Battery2 Indicator

- When the battery 1 or battery 2 is on ,shows the battery 1 or battery 2 is being used. When the battery 1 and battery 2 is on at the same time, indicating that they are currently in parallel, battery 1 and battery 2 are used at the same time.

Long-range display (ODO) :

- Switching mode: In TOTAL state, press M key for 0.5 + 0.25 seconds and switch to TRIP mode.

Short-range display (TRIP) :

- Clearance mode: In TRIP state, press S key for 2 + 0.5 seconds to return TRIP to zero.
- Switching mode: In TRIP state, press M key for 0.5 + 0.25 seconds and switch to ODO mode.

Mileage setting:

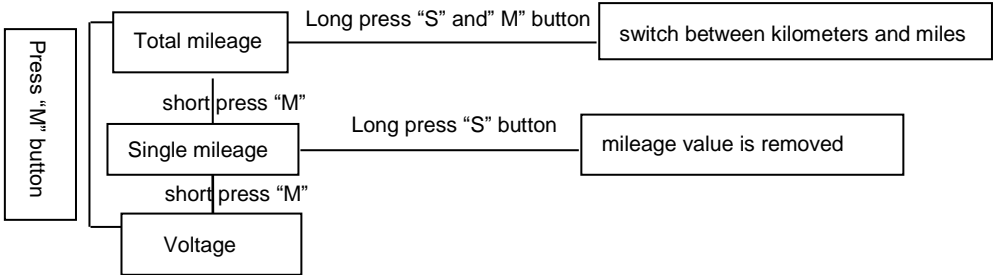

Operation of Main Switch

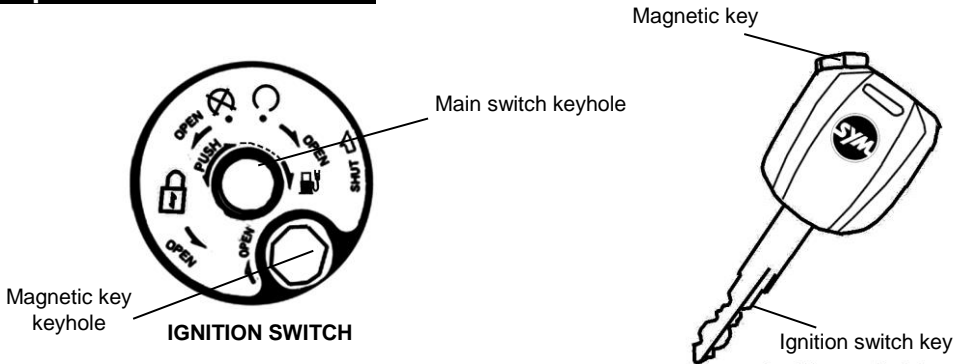

MAGNETIC KEY :

- Align magnetic key and magnetic keyhole and turn right to open the main switch keyhole.
- Align magnetic key and magnetic keyhole and turn left to shut the main switch keyhole.

Main Switch

“ON” position

The motor is on in this position. After unlocking, the scooter is ready for use. The key cannot be removed.

“OFF” position

The motor is off in this position. The key can be removed.

“LOCK” position

Turn the steering handle to left and press the key down and then lightly turn it to lock. The key can be removed.

When unlocking. Simply turn the key from “lock” to “off.”

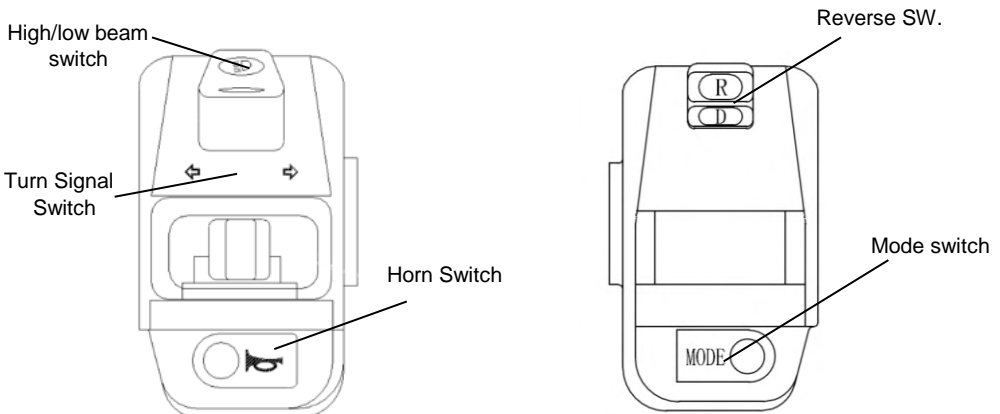

Use of Buttons

Mode Switch

"ECO" mode: Ecology Conservation Optimization mode, It is mainly an energy-saving mode, which can achieve the effect of energy saving by starting it.

"POWER" mode: The power key on the electric vehicle is the power supply and the electric energy warning indicator. It means power on state and power state.

Reverse sw. Switch

When the button is switched to "R" position, it enters the reverse mode. At this time, the electronic handle fails. Long press the "M" button to reverse, with a maximum speed of 5km / h.

CAUTION:

- if the warning indicator light on the electric vehicle does not light when the battery has sufficient power, it is recommended to charge it as soon as possible when the indicator light is on when riding, so as to prevent damage to the battery and shorten the service life of the battery after the remaining power of the battery is exhausted.

Turn Light Switch



Turn the main switch to "ON" position, turn the turn light switch, and the turn light will flash. When using turn light, the turn light signal will flash in accordance with the turn you make.



Near lamp irradiation

Horn Switch



Turn the main switch to "ON" position, press this button, and the horn will sound.

Note on starting to ride

- Before start, you should turn on the turn signal, watch the rear side to make sure no vehicle is coming, and then you can start.

Brake

- Avoid unnecessary sudden braking.
- Use front and rear wheel brakes simultaneously when braking.
- Slow down and brake early when riding in rainy days on slippery roads. Never apply the brakes suddenly to prevent skidding and falling.
- Avoid brake continuously for a long period of time because that may overheat the brakes and reduce its braking efficiency.

⚠CAUTION:

- Using only the front brake or the rear brake increases the risk of falling because the scooter tends to pull to one side.
- When the front or rear brake is operated, speed controller will cut off the power. Be careful when riding the vehicle.

For Rear Wheel

For Front Wheel

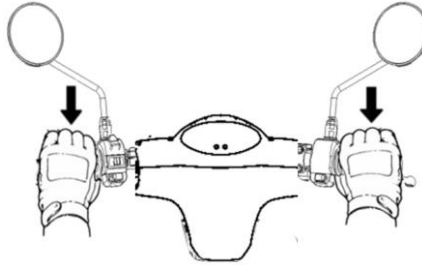

Parking / Shutting Off

1. Turn on the turn signal in advance to warn the vehicles behind. Decelerate and ride to the right side. Reverse the electric throttle and pull front and rear brake levers slowly.
2. Push back the turn signal switch and rotate the main switch key to  to cut motor power off.

⚠CAUTION:

- Do not rotate the main switch key when riding the vehicle to avoid an accident.
- To avoid children from injury and theft, lock the steering handle and removing the key after parking.

3. Park the vehicle on level ground with the main stand.
4. Lock the steering handlebar and remove the key after parking to avoid being stolen.

ELECTRIC THROTTLE INSTRUCTION

Accelerate : Increase riding speed.

- If brake lever is pulled, the electric throttle will be cut off power.

Decelerate : Decrease riding speed.

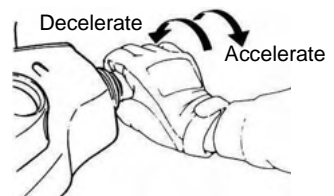

BATTERY CHARGING INSTRUCTION

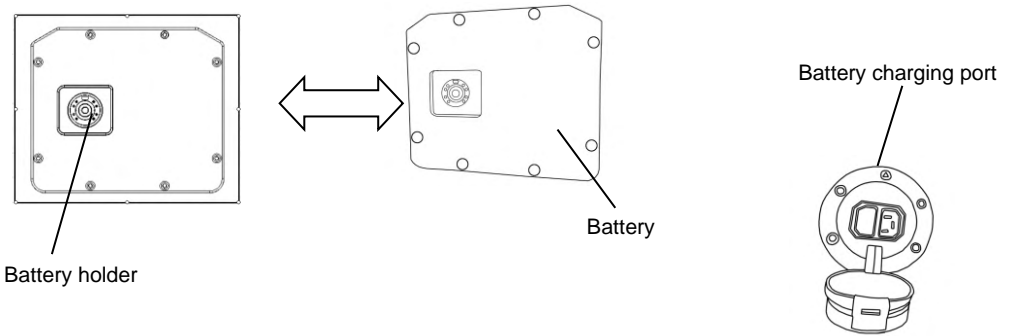

Steps for charging battery on vehicle:

1. Use the main switch to open the vehicle charging port
2. Connect the charger to charge the vehicle, which can be completed in 5 ~ 6 hours
3. Charge the battery directly, please refer to the instructions on the next page
4. After the battery is charged, please make sure that it is installed correctly (the battery is designed with chamfering to ensure that it is installed correctly)

Steps for removing the charger: Reverse the steps of charging.

⚠ CAUTION:

- Store at room temperature. If it is not used for a long time, please put it in a dry and ventilated place and charge it for 2 hours every 1 month
- When connecting the load, it is strictly forbidden to reverse the positive and negative poles
- It is strictly forbidden to dismantle the battery pack without permission, and the label is not warranted for artificial damage
- Do not put the battery into the liquid
- Please use standard charger for charging. If other chargers cause lithium battery abnormality, we will not be responsible
- When unplugging and inserting the battery, the miniature circuit breaker of the body needs to be disconnected and handled with care

⚠ WARNING:

- Please turn off the power and remove the key before charging to avoid children from injury.
- Please charge the battery at a cool place. Keep the battery from high temperature, sun ray, heat, fire, and water.
- Please use SYM authorized charger for charging, or the battery may result in electrolyte leakage, heat, and explosion.
- Installation of lithium battery with foreign matters in the battery box may cause smoke or fire, resulting in casualties.

BATTERY CHARGER USAGE NOTES

Usage Method : The battery can be directly taken out of the vehicle for charging by using the adapter

1. Insert the charger output plug into the charging terminal on the battery.
2. Connect charger cable plug "A" to AC power, and connect charger cable "B" to the charger port.
3. Check LED status indicator.
4. When the battery is fully charged, the green light is always on.
5. Only one battery can be charged by one charger.
6. After charging, disconnect the power supply first and then the battery.

⚠ CAUTION:

- Make sure the charger is connected to the battery tightly.
- Use the battery charger indoors; avoid hot, humid or dusty environment.
- Do not put the charger in the storage box to prevent the charger from being damaged by the violent vibration of the bad road

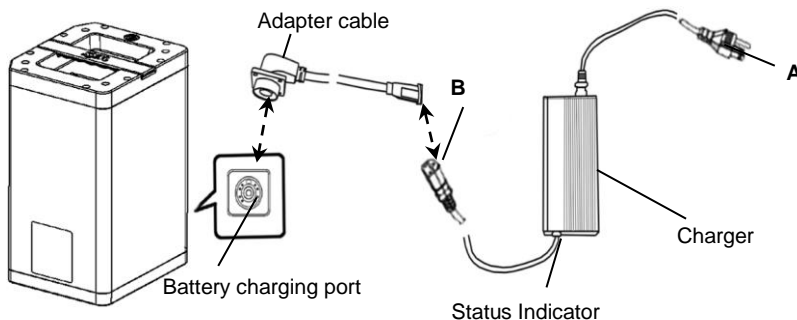

⚠ WARNING:

- Prevent the charger from striking, pressing, and falling.
- Use the charger indoors. Do not place the charger in the luggage box to avoid shocking and moisture.
- Do not place the charger in the luggage box while charging to avoid heat.
- Keep children away while charging.
- Please park the vehicle along the wall or in the corner while charging to avoid tripping people.

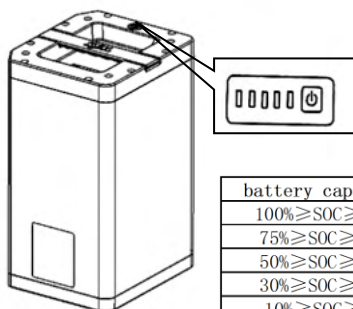

battery capacity	power lamp
$100\% \geq \text{SOC} \geq 75\%$	□ □ □ □ □
$75\% \geq \text{SOC} \geq 50\%$	□ □ □ □ ■
$50\% \geq \text{SOC} \geq 30\%$	□ □ ■ ■ ■
$30\% \geq \text{SOC} \geq 10\%$	□ ■ ■ ■ ■
$10\% \geq \text{SOC} \geq 0\%$	■ ■ ■ ■ ■

□ " means green light is on.

■ " means green light is not on.

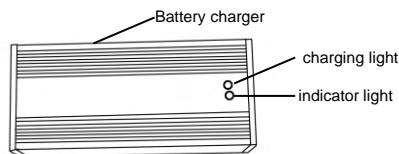

1. the charging indicator light is always on to indicate standby or charging is completed;
2. the charging indicator flashes to indicate that the charging is in progress.
3. generally, the charging is completed in 5-6 hours, and the charging is not completed in more than 14 hours. The charger will enter the timeout protection. It is necessary to check whether the lithium battery is faulty.

INSTRUCTION OF BATTERY USAGE

Specification :

Voltage	60V
Capacity	35.2Ah
Actual capacity	≥33.33Ah
Charging limit voltage	71.4V
Charging environment	0 ~ 45 °C
Discharging environment	-20~60 °C
Working environment humidity	≤80% RH
Weight	15.2kg
Charger specification	71.4V 7A 500W

The charging temperature of lithium battery is 0-45 °C. If need to charge just after riding the vehicle in summer, the temperature of the battery may reach more than 60 °C, which is impossible to charge. The lithium battery will enter the high temperature protection of charging, so you need to cool down for a while before charging

Usage Method :

- Turn off main switch before charging.
- Fully charge the battery before the first ride.
- Charge the battery after each ride.
- Charge at least for 2 hours every 1 month, if the vehicle does not operate for a long period of time.
- Charge the battery on the vehicle. Do not remove the battery.

CAUTION:

- Please use the SYM authorized battery. For safety of electrical parts, do not use unauthorized battery.
- Keep the battery clean. Keep children away while charging.
- If the battery is not used for a long time, please take it out of the vehicle and put it in a dry and ventilated place indoors
- The high temperature, the battery needs to be cooled in a cool place for a certain time before charging

WARNING:

- When deformation, leakage or corrosion occurs to the battery case, stop using the battery immediately and contact your SYM dealer for help.
- Do not disassemble, restructure or destroy the battery.
- Do not dispose the battery or throw it into fire; recycle it at recycle plants or local dealers.
- Do not spray water directly on the controller and battery

Factors that affect the life span of the battery :

- (1) Over Discharge :
 - a. Not in use for long period of time without charging.
 - b. The battery is not recharged when it is empty.
- (2) High-Rate Discharge :
 - a. Frequent riding at max. speed.
 - b. Frequent riding on the slope.
 - c. Frequent riding on the rugged road.
 - d. Over-loaded.
- (3) Others :
 - a. Vehicle parts worn out.
 - b. Charger malfunction.

Battery Charger Usage Method

Charger Usage Instruction:

- Connect charger output cable and battery first, then connect power cable and 100V-240V socket. Two green lights are always on shows charging finished or standby state. One green light is on and one green light is flashes shows the battery is being charged.
- Please use SYM authorized charger.

Dual battery parallel system(EK4LW2-EU/EK2LW2-EU)

When the voltage of the two batteries approaches, the system will automatically enter the parallel state, and the two batteries will be discharged at the same time.

When one battery is high and the other is low, the battery with high voltage will be used preferentially until the voltage of the two batteries is close and enter parallel

CAUTION:

- Please charge the battery indoors, avoid sun ray, moisture, and dust.
- Prevent rain, liquid, foreign metal material from falling into the charger to avoid short circuit or burnout.
- After charging, please remove the cables from the socket to avoid power consuming.
- Do not charge battery of other form and brand with the charger to ensure the life span and safety of the charger and battery.
- Please be sure to use the attached lithium battery charger to charge the lithium battery. If you use other unauthorized chargers or devices for charging, it may cause serious consequences such as smoke and fire of the lithium battery.

CAUTION:

- In normal temperature, the battery can be fully charged in 5-6 hours; however, if the ambient temperature or battery temperature is too high (over 55°C) or too low (under 0°C), to prevent deterioration, the charger will prolong the charging time to 5-7 hours.
- When the temperature of the lithium battery is too high, the controller will intelligently reduce the power to slow down the continuous high temperature of the lithium battery (to protect the lithium battery). When the temperature is reduced, the controller will return to normal power output.
- With the repeated charging and use of lithium battery, the battery capacity will gradually reduce. (when the battery capacity is reduced, even if it is fully charged, the mileage of the vehicle will gradually become shorter.).
- When the vehicle is driving in a very hot or cold place, the endurance mileage of the lithium battery will be reduced. If the power battery returns to the normal temperature of 25 °C, the endurance mileage will also return to normal.
- Even if the electric motorcycle is not used, the lithium battery will gradually self discharge, but the discharge capacity is very small.
- In order to ensure the safety of transportation, the outgoing power of lithium battery is about 30%. Due to the self consumption during the transportation and storage cycle, the first used power is low or there is no power, which is a normal phenomenon. Please don't worry, just charge according to the charging instructions.

WARNING:

- Use independent socket for the charger, do not share the socket with electric equipment to avoid danger and fire.
- Do not disassemble or strike the charger. Warranty will not be applicable if consumers disassemble the charger or there is obvious damage on the charger.
- If the lithium battery is deformed or damaged, do not charge it;
- Do not charge if the lithium battery terminal is rusty;
- If you smell peculiar smell or see smoke during charging, please disconnect the charger immediately and keep away from the lithium battery (quickly transfer the lithium battery to the outdoor open place under the absolute safety condition);
- When charging, please fully plug the charging plug into the power socket or lithium battery socket;

Controller unlocking

When it is powered on for the first time, the controller is locked. At this time, it is unable to ride and needs to unlock the controller.



Hold the brake and press the mode button for more than 0.1 second to unlock

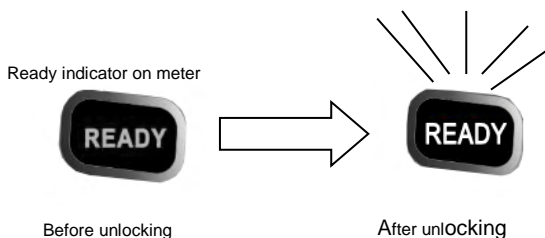

When the vehicle is not riding after the first unlocking, the vehicle will automatically lock after 5 seconds (ready light goes out). When the vehicle is not riding again, it will still lock again until the vehicle moves. After the vehicle kicks the side stand (with side stand flameout switch), it is equivalent to turning off the controller, which needs to be unlocked again.

In the process of riding, if the vehicle stops, the key is not closed, the side stand is not turned on, the controller is locked after 5S, and the brake needs to be pulled again to unlock.

Battery over temperature protection:

During the ride, if the weather is hot and the heat is emitted by lithium battery during riding, the temperature of lithium battery may be too high. In order to protect the battery, the output power of the battery will be reduced, so that the battery will not be ultra high temperature, overload operation and life of the battery will be prolonged. After power reduction, the vehicle speed will be reduced to about 20km/h. The instrument will light up the battery warning light until the battery temperature will be lower than the safety range and then recover.

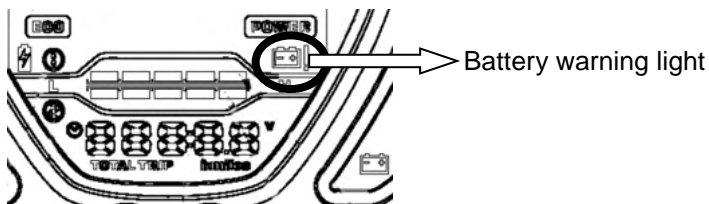

TIRE INSPECTION

- Tires should be checked and inflated when the engine is off.
- If a tire's ground contacting curve is abnormal, check it with a tire pressure gauge and inflate it to the specified pressure.
- Tire pressure must be checked with a tire pressure gauge when the tire is cold.

⚠ CAUTION:

- If the tire pressure is insufficient, it will affect the riding range of the vehicle and the life span of the battery and motor. Tire pressure inspection is suggested every month.

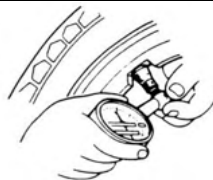
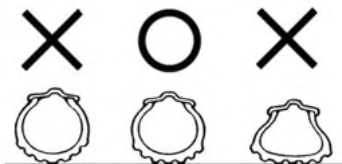

PLEASE REFER TO SPECIFICATIONS FOR STANDARD TIRE PRESSURE

- Visual check tires for frontal and lateral side walls for crack or damage.
- Visual check tires for any nails or small stones wedged in the tread.
- Check the “tread wear indicator” condition to see if tread groove depth is insufficient.
- A tire with a wear bar showing is worn out and should be replaced immediately.

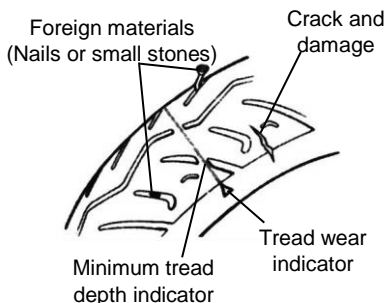

STEERING HANDLEBAR INSPECTION

- Switch off the power and remove the key before inspecting.
- Visual check the front shock absorbers for any damage.
- Operate the steering handlebar up and down, and check the front shock absorbers for noises due to bends.
- Check the bolts and nuts of front shock absorbers with wrenches for tightness.
- Shake the steering handlebar up & down, left & right, and front & rear to check if it is loosen or pulled to one side.
- Check the steering handlebar if it is pulled too tight by the brake cables.
- Take your vehicle to SYM Authorized Dealer for a check or adjustment if abnormal conditions are found.

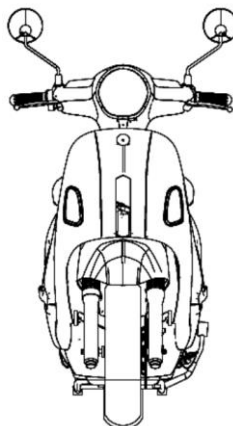

Checking front brake lining

- Check the brake from behind the brake caliper. The brake pad must be replaced with new lining when the brake pad wear limit reaches the brake disk.

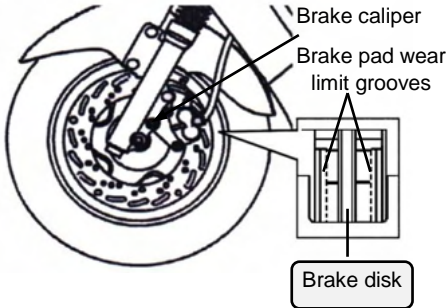

Checking oil quantity in brake oil reservoir

- Park the scooter on a level ground, and check if fluid level is under the "LOWER" mark. Recommended Brake Fluid: WELL RUN BRAKE OIL (DOT 3).

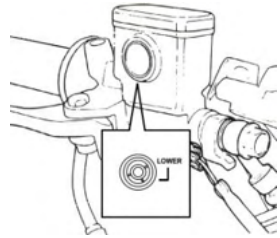

Replenishment of front wheel brake fluid

1. Loosen the screws and remove the master cylinder cover.
2. Wipe clean foreign materials, dirt around the reservoir, be careful not to let foreign materials fall into the reservoir.
3. Remove the diaphragm plate and the diaphragm.
4. Add brake fluid to upper level.
5. Install the diaphragm plate and the diaphragm, and install the master cylinder cover.
6. Please note the diaphragm direction, and do not let foreign materials fall into the reservoir. And tighten the master cylinder cover securely.

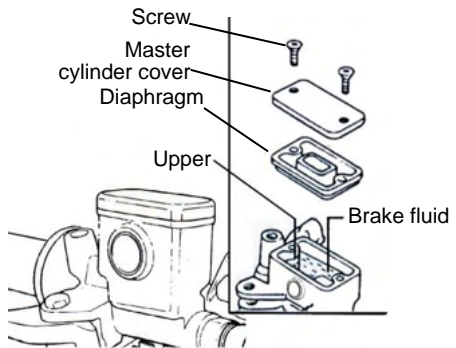

⚠ CAUTION:

- To prevent chemical reaction, please do not use brake fluids other than those recommended.
- Do not fill above the upper limit when adding brake fluid and avoid dropping on painting or plastic components to prevent damage.

INSPECTION AND ADJUSTMENT OF BRAKE FREE PLAY

INSPECTION : (Brake lever free play must be checked with the engine off.)

- Brake lever free play for front and rear wheels.

When checking the hand-braking lever for front and rear wheels, its free play (the stroke of hand-braking lever from no braking to initial braking) should be 10~20mm. It is abnormal if the feel is spongy when holding the hand-braking lever forcefully.

Adjustment : (If install disk type)

The indentation of brake adjustment nut must be aligned with the pin. (see below figure)

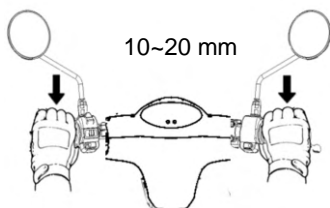

⚠ CAUTION :

When free play is between 10~20 mm, check brake indicators of front and rear wheels. If the arrow on the brake arm aligned with the "△" marked on the brake disk, that means the brake lining has been excessively worn, and must be replaced immediately.

Turn the adjustment nut on brake arm of front and rear wheels to adjust the free play of hand-brake lever.

- Hold the hand-brake levers after adjusting with both hands until there is effective brake feeling.
- Measure the free play with a ruler.

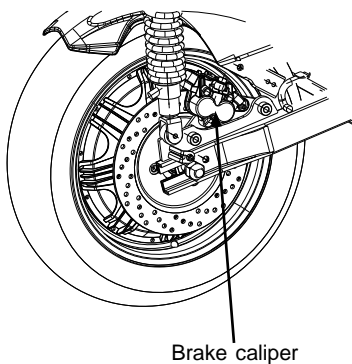

MAINTENANCE

1. Routine Maintenance

- Turn off the main switch and remove the key before performing inspection and maintenance.
- Clean the dust and mud around the motor and every part of the vehicle periodically.
- Check if the brake, light and tire operate normally.
- Check if the screws or bolts are loose; adjust them properly.

CAUTION:

- Do not spray the vehicle body and motor with high pressure water to avoid affecting the performance and life span of the vehicle.
- Use neutral cleanser and soft cloth to wash and wipe the vehicle.

2. Periodical Maintenance

- Periodical inspection and maintenance at SYM dealer every month is suggested to lengthen the life span and riding safety of the vehicle.

INSTRUCTION OF MOTOR USAGE

Specification :

NO	Type	standards
1	Rated speed (r/min)	520±3%
2	No-load current (A)	≤3
3	No-load speed (r/min)	540±3%
4	Rated power (W)	1500
5	Rated voltage(V)	60

Caution

- Please avoid overload, steep slope, and long period of power-consuming condition; it may damage battery, motor controller, and motor.
- Do not spray high pressure water toward motor assembly.
- Do not ride across the flooded road over 10cm high.
- Do not disassemble the motor assembly.

CONTROLLER USAGE INSTRUCTION

Specification:

Rated operating voltage: DC60V; speed regulating voltage: DC0.8-4.2V; blocking current: $\leq 40A$

Usage Method :

- Avoid rotating the electric throttle rapidly; high current operation may lead to high temperature of the motor controller.

Function :

- Controlling the current intensity, braking cutoff protection, malfunction cutoff protection, rotation-clogging protection and over-heating protection.

CAUTION:

- Avoid long time solarization, rain to secure the controller.
- Do not disassemble the controller.

Troubleshooting

	Detection Item	Possible Causes	Countermeasures
1	Unable to charge	Not using SYM authorized battery	Using SYM authorized battery
		Low input voltage	Power input 100V~240V
2	Long time charging without green light on	Battery deterioration or malfunction	Replace battery
3	Meter doesn't work and indicator doesn't illuminate.	Power cable of battery is not connected.	Reconnect the power cable and then switch on.
		Battery inner cable loose	Reconnect the inner cable and then switch on.
		Main switch coupler loose	If the coupler is loose, reconnect it. If the coupler is ok, there might be open circuit in the wire harness. Please contact your SYM dealer.
		Main switch malfunction	Replace the main switch
		Low battery voltage	1 Recharge the battery. Check if the battery voltage is 60V. 2. Replace the battery when the voltage is under 30V after recharging.
4	Malfunction of light system	DC / DC Converter malfunction	1. Check the appearance and harness for abnormality 2. Check whether the positive and negative poles of DC are short circuited (including input and output) 3. When the whole vehicle is powered on, check whether the measured voltage is abnormal (i.e. measured with a multimeter, the output voltage shall be $13.5V \pm 0.5V$) 4.Contact your SYM dealer.
5	Rear wheel does not rotate when the electric throttle is rotated.	Faulty main switch	Replace the main switch
		Motor wire loose	Reinstall
		Ineffective motor position feedback signal	Contact your SYM dealer
		Motor malfunction	
		Motor controller overheated	
Motor controller malfunction			
6	Riding mileage is too short.	Front / rear brake too tight	Adjust front / rear brake.
		Long time without charging	Recharge after riding or when the vehicle is not in use for a long time.
		Low temperature	Battery quantity will decrease when the temperature is low.
		Low tire pressure	Check the tire pressure periodically (every month) and inflate the tire to the recommended pressure.
		Aged battery	Replace the battery

Specification:

type		EK4LW1-EU/EK2LW1-EU/EK4L2-EU/EK2LW2-EU	
Length×width×height (mm)		1860(±20)×680(±20)×1115(±20)	
Weight(kg)/ Wheelbase (mm)		95(±6)/1315(±20)	
Minimum radius of rotation		EK4L:40N·m/480 rpm	EK2L:70N.m/210 rpm
Motor	type	60V1500W	
	Motor Model	RBNFFCK	
	maximum power	EK4L:2.0Kw	EK2L:1.6Kw
Motor Controller	Voltage	60v	
	No-load current	≤3A	
Battery	type	Li-Battery	
	Voltage	60V	
	capacity	35.2A/h	
Controller Model		EK4L:60V40A 45KM/h	EK2L: 60V40A 25KM/h
Undervoltage protection value		52V	
Overcurrent protection value		40A	
Maximum Speed		EK4L:45km/h	EK2L: 25km/h
License light		12V 0.204W	
Headlights (High beam, near)		12V 10.68W/10.68W	
Position lamp		12V 1.08W	
Taillight/stoptlight		12V 0.588W/2.64W	
Turn signal light (front/rear)		12V RY 10W*2/12V RY 10W*2	
Fuse		15A×4	
Front brake		disk (Φ226)	
Rear brake		disk (Φ220)	
Front wheel		110/70-12	
Rear wheel		120/70-12	
Tyre pressure (2 riders)		front : 175 kpa / rear : 200 kpa	
Maximum load capacity		front : 8kg / rear : 30kg	

SYM Electric Scooter Q & A:

1. How is the SYM electric scooter capability of riding across flooded road? Is the motor waterproof?
A: The motor is capable of being drenched, but the waterproof capability is not good when being soaked. Do not ride across the flooded road when the water level is higher than the wheel rim (approximately 10cm high).
2. Can SYM electric scooter be ridden in the rainy day? How is the waterproof capability?
A : Yes, but do not ride across the flooded road when the water level is higher than the wheel rim (approximately 10cm high), or the motor could possibly suffer from being soaked (the waterproof capability of motor depends on the gasket adhesive; the waterproof capability can not be guaranteed after disassembly). Spraying on the motor and wire harness with high-pressure water is extremely prohibited, which will result in short circuit.

If equipped with USB charging function, do not use it in rainy days
3. What will happen to the battery and motor if the vehicle is soaked in the water with the water level higher than the footrest when the main switch is key-off? What will happen if the water level is higher than the footrest when the main switch is key-on?
A : The motor, motor controller and DC-to-DC converter could be possibly damaged because of being soaked when the water level is higher than the footrest. The damage would be worse if the main switch is key-on. Only the battery could possibly survive damage, but might malfunction because of short circuit caused by other parts' damage.
4. Can SYM electric scooter carry passenger or cargo?
A : It can't carry passengers, but it can carry cargo. The load capacity of the front shelf is 8kg, and the load capacity of the rear shelf is 30kg
5. Battery charger input voltage ?
A : Use the electrical socket (220V)
6. How long is the charging period?
A : 1. The battery needs to be charged 4-5 hours (20Ah) · In the situation that the ambient temperature or the battery temperature too high (more than 45°C) or too low (less than 0°C), to avoid battery deterioration, the battery will automatically prolong the charging time to 5-7 hours.
2. It is recommended to recharge after each ride to prolong battery service life.
3. In long time not in use, it is recommended to fully charge the battery every 3 months to prolong battery service life.
7. Is there any side effect when the charger is still plugged to the electrical socket after the battery is removed?
A: The charger will not be heated when it is plugged to the electrical socket, but would consume standby power.
8. How much will the riding range decrease when the headlight is turned on?
A: Approximately 10~20% less.